

**LARGE PROPELLER  
SUBMERSIBLE MIXER**  
THE ENERGY SAVING LOW-SPEED AGITATORS  
FROM THE STIRRING PROFESSIONALS

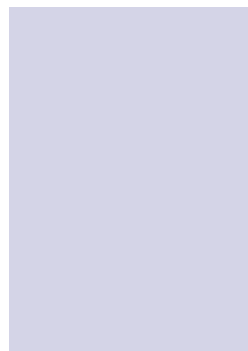
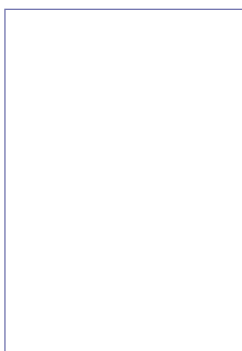

## MODULAR DESIGN

WITH THE WIDE RANGE OF INDIVIDUAL COMPONENTS AVAILABLE (SUBMERSIBLE MOTORS, GEARBOXES, PROPELLERS, MONITORING DEVICES AND ACCESSORIES), IT IS POSSIBLE TO CONFIGURE A SUITABLE SUBMERSIBLE MIXER FOR ALMOST ANY APPLICATION. IT IS NOW POSSIBLE TO OPTIMIZE PROPELLER PERFORMANCE FOR ANY PARTICULAR APPLICATION BY USING DIFFERENT TRANSMISSION RATIOS AND PROPELLER CHARACTERISTICS (DIAMETERS, MATERIALS AND PROFILES).

THIS INCREASES THE AGITATOR EFFICIENCY AND SERVICE LIFE AND REDUCES ENERGY COSTS.

THE STANDARD FEATURES OF OUR NEW SERIES WITH MOTOR OUTPUTS FROM 1,5 TO 11 KW INCLUDE SILICON CARBIDE MECHANICAL SEALS (MOTOR AND PROPELLER SHAFT) A TEMPERATURE MONITOR ON THE MOTOR WINDING AND A HIGH-VOLUME OIL CHAMBER WITH SEAL MONITOR.

## APPLICATION RANGE:

MEDIA / SUBSTRATES AT TEMPERATURES UP TO 60°C  
ACTIVATED SLUDGE BASINS  
BIOLOGICAL TREATMENT  
DENITRIFICATION  
INDUSTRIAL PROCESSING  
BIOGAS PLANTS / ENVIRONMENTAL ENGINEERING  
APPLICATIONS WITH EXPLOSION-PROOF REQUIREMENTS

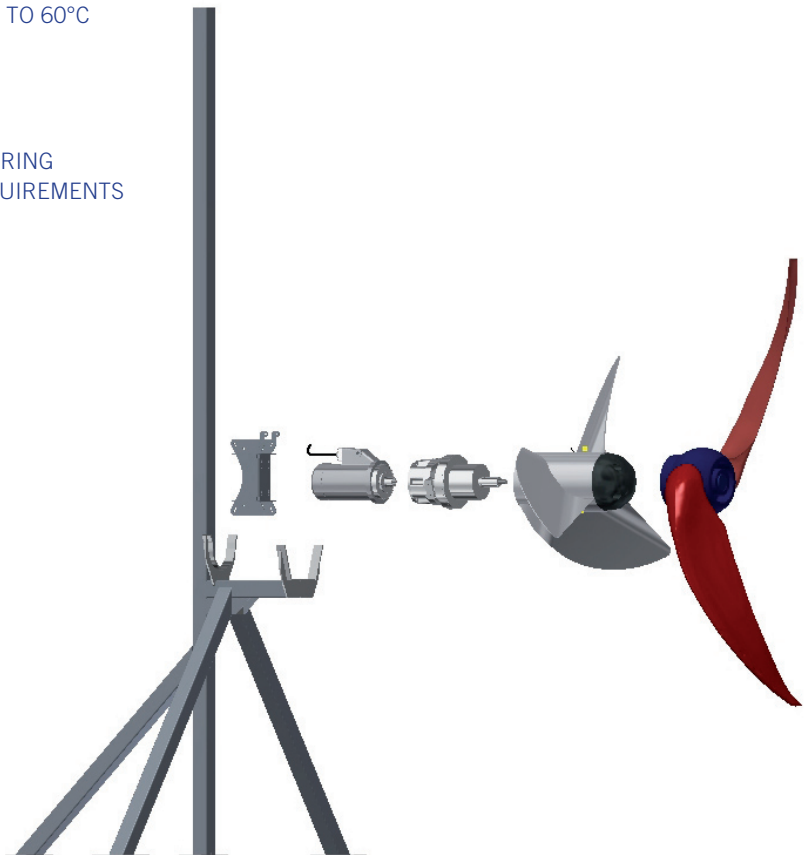

## IDEAL AND EFFECTIVE PERFORMANCE

WITH THEIR LARGE PROPELLER DIAMETERS AND LOW SPEED THESE AGITATORS GENERATES MAXIMUM THRUST. FREEDOM IN POSITIONING AND ORIENTATION OFFERS THE POSSIBILITY TO ADAPT THE MIXING STREAM TO THE SHAPE OF THE TANK. THE SELF-CLEANING PROPELLER ENSURES A CONSTANTLY HIGH STIRRING PERFORMANCE AND A VIBRATION FREE OPERATION EVEN IN FIBROUS MATERIAL.

## LOWEST ENERGY CONSUMPTION

BY USING PROPELLERS WITH OPTIMUM HYDRAULIC DESIGN, VARIABLE GEAR RATIOS AND HIGHLY EFFICIENT MOTORS (IE2 OR IE3 ACCORDING TO IEC60034-30) A MAXIMUM OVERALL EFFICIENCY IS BEING ACHIEVED. THIS REDUCES THE ENGERY COSTS.

## SEALING SYSTEM

IN PRACTICE, THE RELIABILITY AND DURABILITY OF THE SHAFT SEALS HAVE BEEN FOUND TO BE CRUCIAL FOR A TROUBLE-FREE OPERATION. THE SEALING SYSTEM STREISAL SEAL GUARD OFFERS A NUMBER OF ADVANTAGES:

- TWO HIGH-ABRASION-RESISTANT SILICON CARBIDE MECHANICAL SEALS (TANDEM VERSION) ARE BEING USED TO SEAL THE PROPELLER SHAFT.
- GLIDE RINGS PROTECTED BY SEALING RETAINER IN STAINLESS STEEL
- INTERNAL SPRING ELEMENTS WHICH DO NOT COME INTO CONTACT WITH THE MEDIA

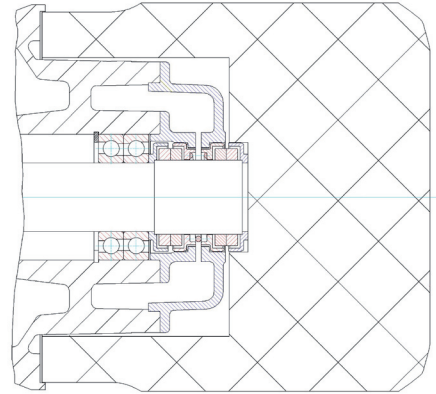

Tandem version streisal Seal Guard

### TECHNICAL DATA:

Type	Nominal Power P2 [kW]	Nominal Current [A]	Circulation Power <sup>*)</sup> [m <sup>3</sup> /h]	Propeller Speed [U/min]	Axial Thrust [N]
BTP 74	7,5	13,8	7.250	59	2.640
BTP 114 <sup>**)</sup>	11,0	21,5	8.950	59	3.500
ATP 16	1,5	3,55	7.560	22	800
ATP 26	2,2	6,5	9.800	27	1.650
ATP 34	3,0	8,3	11.650	26	1.900
ATP 44	4,0	10,1	13.000	32	2.900
ATP 54	5,5	13,8	14.300	38	3.500
ATP 74	7,5	21,5	15.310	40	4.000

<sup>\*)</sup> Circulation power in flow profile <sup>\*\*)</sup> Energy-efficiency class IE1

MOTOR 400+/-5% VAC, IE2 (IE3 ALSO AVAILABLE), NOMINAL FREQUENCY 50 HZ, PROTECTION CLASS MOTOR IP 68

#### SAFETY:

MOTOR WITH FLAMEPROOF ENCLOSURE  
 EXPLOSIVE ATMOSPHERE PROTECTION ACCORDING TO ATEX  
 PTC THERMISTORS TO PROTECT AGAINST THERMAL OVERLOAD  
 SEALING SYSTEM MONITORED BY STREISAL TOPLIMITER IN TANDEM VERSION,  
 I.E. WITH TWO SEALS AND OIL CHAMBER UPSTREAM.

## DIMENSIONS AND WEIGHTS:

Type	D	L	L1	Weight [kg] <sup>*)</sup>
BTP 74	1.400	1.375	405	280
BTP 114	1.500	1.375	405	292
ATP 16	2.650	1.630	380	295
ATP 26	2.400	1.630	380	295
ATP 34	2.650	1.630	380	300
ATP 44	2.400	1.630	380	300
ATP 54	2.400	1.630	380	305
ATP 74	2.400	1.630	380	310

<sup>\*)</sup> Agitator without carriage

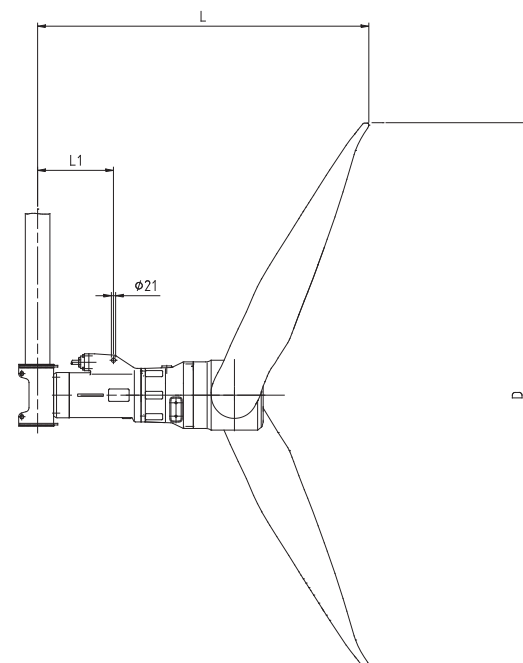
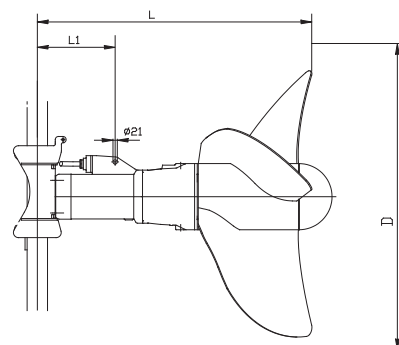

## MATERIALS:

CASING	GG25
SEALING RETAINER	STAINLESS STEEL 1.4301/ AISI 304 (V2A)
CONNECTORS	STAINLESS STEEL 1.4301/ AISI 304 (V2A)
PROPELLER BTP	STAINLESS STEEL 1.4301/ AISI 304 (V2A)
PROPELLER ATP	HIGH STRENGTH, WEAR FREE POLYMER WITH STEEL CORE
MOTOR SHAFT	1.7225 (NOT IN CONTACT WITH MEDIA)
MECHANICAL SEALS	SILICON CARBIDE
CARRIAGE	STAINLESS STEEL 1.4301/ AISI 304 (V2A)
CORROSION PROTECTION	INERTOL POXITAR COATING CERAMIC COATING OR SIMILAR FOR AGGRESSIVE MEDIA OR ACCORDING TO CUSTOMER REQUIREMENT

## FIRST CLASS ACCESSORIES

STREISAL'S RANGE OF ACCESSORIES REPRESENTS MORE THAN 20 YEARS EXPERIENCE FROM MEETING ALL SORTS OF REQUIREMENTS FROM A VARIETY OF DIFFERENT INDUSTRIES. AS A RESULT, OUR PRODUCTS ARE KNOWN FOR THEIR HIGH QUALITY AND DURABILITY. SINCE THEY ARE PERFECTLY MATCHED TO OUR AGITATORS, THEY FACILITATE INSTALLATION, OPERATION AND MAINTENANCE.

(TECHNICAL CHANGES, ERRORS AND OMISSIONS EXCEPTED)

**CONTACT:** STREISAL GMBH PETTERMANDSTRASSE 2 88239 WANGEN IM ALLGÄU  
TEL +49(0)7522-707965-0 FAX +49(0)7522-80450 WWW.STREISAL.DE INFO@STREISAL.DE

